

9-12-2018

Making Room for Moms: Advocating for a Lactation Space in the Library

Heidi Blackburn

University of Nebraska at Omaha, hblackbu@gmail.com

Joyce Neujahr

University of Nebraska at Omaha, jneujahr@unomaha.edu

Follow this and additional works at: <https://digitalcommons.unomaha.edu/crisslibfacproc>

 Part of the [Higher Education Commons](#), and the [Library and Information Science Commons](#)

Please take our feedback survey at: https://unomaha.az1.qualtrics.com/jfe/form/SV_8cchtFmpDyGfBLE

Recommended Citation

Blackburn, Heidi and Neujahr, Joyce, "Making Room for Moms: Advocating for a Lactation Space in the Library" (2018). *Criss Library Faculty Proceedings & Presentations*. 95.

<https://digitalcommons.unomaha.edu/crisslibfacproc/95>

This Presentation is brought to you for free and open access by the Dr. C.C. and Mabel L. Criss Library at DigitalCommons@UNO. It has been accepted for inclusion in Criss Library Faculty Proceedings & Presentations by an authorized administrator of DigitalCommons@UNO. For more information, please contact unodigitalcommons@unomaha.edu.



UNO LIBRARIES

Making Room for Moms: Advocating for a Lactation Space in the Library

Dr. Heidi Blackburn, STEM and Business Librarian
Joyce Neujahr, Director of Patron Services

Seeing the need

Women make up:

- 80% of the library workforce
- 56% of the student body in higher education
- 53% of the faculty, staff, and administration in public universities in the U.S.



Photo courtesy of University of Nebraska Communications 2018

- <https://www.bls.gov/cps/>
- <https://nces.ed.gov/fastfacts/display.asp?id=372>
- <https://www.chronicle.com/article/Gender-RaceEthnicity-of/240488?cid=cp134>

Finding best practices

- Ask the moms to be! (Staff input)
- Read the literature – What are other institutions doing? What are industry leaders doing?
- Find an expert – UNO Gender and Sexuality Resource Center director was armed with best practices
- Learn from mistakes – feedback about other campus lactation spaces that didn't quite work



Photo courtesy of University of Nebraska Communications 2018

Working with administration

- Budget crisis
- Cost savings vs efficiencies
- Who's on first?
- Navigating political waters



<https://vimeo.com/213149910>

Building awareness of the problem

“I’m not the one who started the project. I’m just the loudest.” ~Heidi

- UNO Libraries begins to talk about needs, February 2017
- CCSW advocates with UNO’s Chancellor, June 2017
- Follow up, December 2017
- Follow up, March 2018
- Follow up, May 2018
- Plans arrive, Summer 2018
- Now taking bids, Fall 2018!



CCSW co-chairs with UNO Chancellor Gold (2018 CCSW luncheon)

Current status

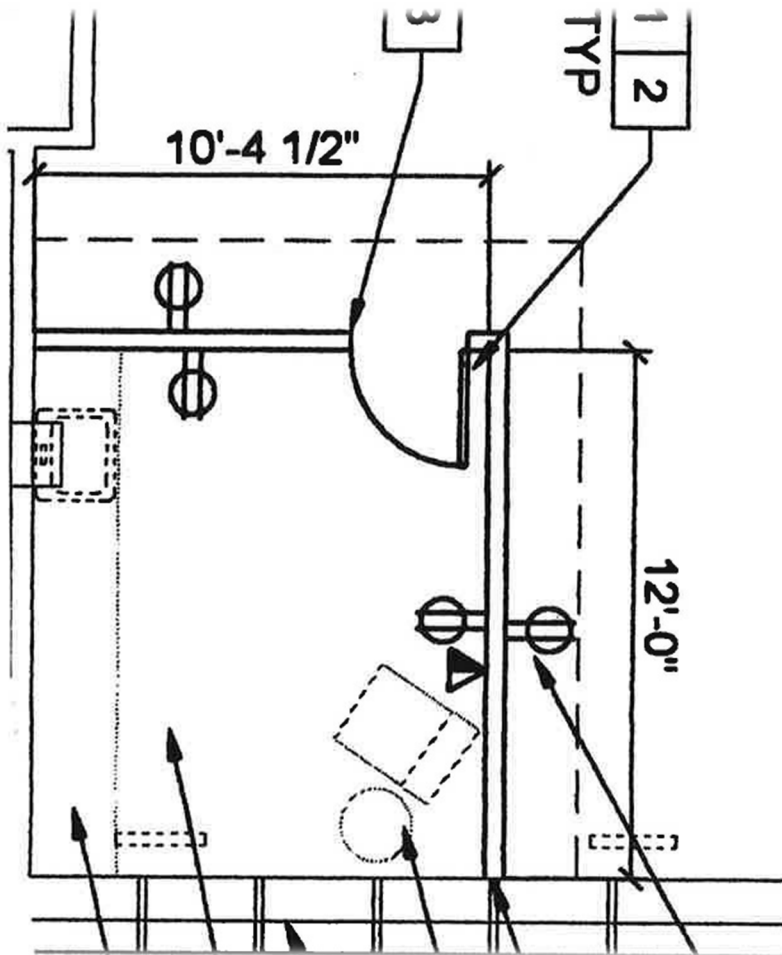

Current status



Current status



Current status





Lessons learned

- Advocating with administration
 - Always be ready to speak up
 - Have your two-minute ask ready
- “Women’s problems are everyone’s problems”
 - How do I explain that my cause is your cause?
- What is the long game?
 - Are you prepared to ask for a month? A year?
 - How is this serving your patrons in the end?

Lessons learned

- Practical amenities
 - Sink for cleaning supplies
 - Refrigerator (pros and cons)
- Lock on the door
 - We have an online booking system
 - Key will be checked out at the main service desk
- Signage
 - Lactation room or Mother's room?





Lessons learned

- Complete individual privacy
 - Communal space for moms who want to be in the company of other mothers while pumping
- Ergonomically designed furniture
 - Nursing is different than pumping
- Furniture that is easily cleaned from spills
- Functional yet stylish ambiance
 - Invites mothers to decompress and recharge
 - Allows them to return to their work feeling energized, appreciated and productive

We are including:

- Changing table
- Chair, footrest, side table
- Baby wipes, paper towels, hand sanitizer, tissues
- New parent books, magazines
- Small children table and chairs
- Children books and games
- Additional seating for two more adults or Mom and child(ren)
- Help button to service desk
- Dimmable lighting
- Ceiling light/fan
- Noise reduction
- Art work
- Whiteboard for Moms to leave messages to each other
- Cork board to pin a picture of your baby up
- Mirror
- Natural light with frosted glass



UNIVERSITY OF
Nebraska
Omaha



The University of Nebraska does not discriminate based on race, color, ethnicity, national origin, sex, pregnancy, sexual orientation, gender identity, religion, disability, age, genetic information, veteran status, marital status, and/or political affiliation in its programs, activities, or employment.

