

10-27-2020

A randomized controlled trial of the impact of body-worn camera activation on the outcomes of individual incidents

Jessica Huff

University of Nebraska at Omaha, jessiehuff@unomaha.edu

Charles M. Katz

University of Nebraska at Omaha

E. C. Hedberg

Follow this and additional works at: <https://digitalcommons.unomaha.edu/criminaljusticefacpub>

 Part of the [Criminology Commons](#)

Please take our feedback survey at: https://unomaha.az1.qualtrics.com/jfe/form/SV_8cchtFmpDyGfBLE

Recommended Citation

Huff, J., Katz, C.M., & Hedberg, E.C. (2020, October 27). A randomized controlled trial of the impact of body-worn camera activation on the outcomes of individual incidents. *Journal of Experimental Criminology*, 18, 247-272. <https://doi.org/10.1007/s11292-020-09448-5>

This Article is brought to you for free and open access by the School of Criminology and Criminal Justice at DigitalCommons@UNO. It has been accepted for inclusion in Criminology and Criminal Justice Faculty Publications by an authorized administrator of DigitalCommons@UNO. For more information, please contact unodigitalcommons@unomaha.edu.

A randomized controlled trial of the impact of body-worn camera activation on the outcomes of individual incidents

Jessica Huff¹, Charles M. Katz¹, & E. C. Hedberg²

¹ Center for Violence Prevention and Community Safety, School of Criminology and Criminal Justice, Arizona State University, 411 N. Central Ave, Suite 680, Phoenix, AZ 85004-0685, USA

² NORC at the University of Chicago, Boston, MA, USA

Abstract

Objectives Evaluate the impact of body-worn cameras (BWCs) on officer-initiated activity, arrests, use of force, and complaints.

Methods We use instrumental variable analysis to examine the impact of BWC assignment and BWC activation on the outcomes of individual incidents through a randomized controlled trial of 436 officers in the Phoenix Police Department.

Results Incidents involving BWC activations were associated with a lower likelihood of officer-initiated contacts and complaints, but a greater likelihood of arrests and use of force. BWC assignment alone was unrelated to arrests or complaints; however, incidents involving officers who were assigned and activated their BWC were significantly more likely to result in an arrest and less likely to result in a complaint.

Conclusions Future researchers should account for BWC activation to better estimate the effects of BWCs on officer behavior. To maximize the effects of BWCs, police agencies should ensure that officers are complying with activation policies.

Keywords

Arrest, Body-worn cameras, Complaints, Compliance, Instrumental variable analysis, Officer-initiated activity, Policing, Use of force

Body-worn cameras (BWCs) are being deployed at an accelerated rate in police agencies across the US. The expansion of this technology has been promoted to increase police effectiveness through enhanced ability to capture evidence and to reduce police use of force and citizen complaints against the police as a result of increased self-awareness or a civilizing effect (Ariel et al. 2015; White 2014). However, some researchers have raised concerns that additional external review of officer

behaviors can lead to de-policing or officer passivity (Rushin and Edwards 2017). Though a growing body of research has assessed the impact of BWCs on outcomes including officer passivity, arrests, use of force, and citizen complaints, the findings are far from conclusive (Lum et al. 2019). Further, the studies examining the impact of BWCs on officer behavioral outcomes have often focused on either officer-level or agency-level change, as opposed to examining the impact of BWCs on the outcomes of individual incidents.

The purpose of this study is to examine the impact of BWCs on officer-initiated activity, arrests, officer use of force, and citizen complaints against officers using data collected as part of a randomized controlled trial (RCT) of BWCs in the Phoenix Police Department. We advance prior research by examining both the impact of being assigned to wear a BWC and the impact of BWC assignment for incidents where the BWC was activated. This analysis focuses on the outcomes of individual incidents. Given prior research finding a wide range of officer compliance with BWC activation policies (Lawrence et al. 2019), accounting for whether BWCs are activated by officers who are assigned to wear them is important and adds to the methodologies previously used by Hedberg et al. (2017).

Literature review

The rapid expansion of BWCs in the US has sometimes been attributed to a “crisis in policing.” In response to this crisis, the President’s Task Force on Twenty-First Century Policing promoted the use of BWCs to increase police transparency and accountability (President’s Task Force on 21st Century Policing 2015). The adoption of BWCs in response to this recommendation (often supported by federal funding) has led to a large body of work evaluating BWCs. These evaluations often examine the impact of BWCs on officer activity levels, use of force, and/or the number of complaints filed against police officers. While some researchers randomly select officers and mandate them to wear BWCs (e.g., Peterson et al. 2018), others have used officers who volunteer to wear a BWC (e.g., Braga et al. 2017). This section reviews prior BWC research, the differences between research designs, and how these differences might impact research findings.

BWCs and officer activity

BWCs are expected to influence officer activity levels through increasing the evidence an officer can collect and/or constraining officer use of discretion. This could result in increases in officer-initiated contacts and arrests. For instance, Ready and Young (2015) suggested that BWCs could make officers more proactive because BWCs can be used to record evidence of the suspicious activities that an officer witnesses. They found that incidents involving BWC officers were more likely to be officer-initiated and to result in a citation (but not arrest). They attribute their findings to the potential for officers who wear BWCs to be concerned about not responding formally to incidents when there is video evidence of the offense (Ready and Young 2015).

Several researchers have examined whether BWCs influence officer proactivity, though findings are inconsistent across studies (Huff et al. 2020a). Researchers in Mesa (AZ) and Spokane (WA) found that BWC officers engaged in significantly higher levels of officer-initiated contacts than control officers (Ready and Young 2015; Wallace et al. 2018). These findings counter concerns that BWCs could result in officer passivity. Similarly, officers in Hallandale Beach (FL) conducted a higher number of field contacts after being assigned to wear a BWC, though this increase was not significantly different compared to control officers (Headley et al. 2017). In contrast, researchers in Milwaukee (WI) found that BWC officers engaged in significantly fewer subject stops compared to control officers, and identified no differences in officer-initiated activities between groups (Lawrence and Peterson 2019; Peterson et al. 2018). They suggest that the BWC officers in their study were more selective in the types of proactive contacts that they engaged in (Lawrence and Peterson 2019). Finally, researchers in Las Vegas (NV), London (UK), Louisville (KY), and Tempe (AZ) found no relationship between BWCs and officer proactivity (Braga et al. 2018; Grossmith et al. 2015; Hughes et al. 2020; White et al. 2018).

Arrests are another measure used to examine the influence of BWCs on officer activity levels. Like officer-initiated activities, researchers examining the impact of BWCs on arrest have uncovered mixed findings (Huff et al. 2020b; Lum et al. 2019). In both Las Vegas (NV) and Phoenix (AZ), officers assigned to wear a BWC conducted a significantly greater number of arrests than officers assigned to the control group (Braga et al. 2018; Katz et al. 2014). These findings are supported in agencies outside of the US as well, as officers wearing BWCs in the Plymouth Constabulary (England) and the Toronto Police Service (Canada) conducted more arrests than officers who were not using BWCs (Goodall 2007; Whynot et al. 2016). Braga et al. (2018) suggest that the increase in arrests associated with BWCs could be due to additional evidence that can be used to hold offenders accountable, or to perceived constraints on officer discretion that result in officers deferring to arrests to avoid potential discipline for failing to conduct an arrest. However, researchers in Hallandale Beach (FL) and a southwestern US agency found that officers conducted fewer arrests after being assigned to wear a BWC (Headley et al. 2017; McClure et al. 2017). Several studies have identified no relationship between BWCs and arrests (Grossmith et al. 2015; Hedberg et al. 2017; Ready and Young 2015; Wallace et al. 2018; Yokum et al. 2017). Given the mixed findings across these prior studies, the influence of BWCs on arrests is somewhat unclear.

BWCs and officer use of force and citizen complaints

Early studies that identified dramatic reductions in officer use of force and citizen complaints resulted in increased pressure for police agencies to adopt BWCs. For example, researchers in Rialto (CA), Las Vegas (NV), and Miami (FL) have found that officers wearing BWCs use force significantly less often than control officers (Ariel et al. 2015; Braga et al. 2018; Chin-Quee 2018). Ariel et al. (2015) suggest that the reduction

in use of force associated with BWCs was likely driven by a deterrent effect, which resulted in officers exhibiting more desirable behaviors when their actions were being recorded. Though the research to date generally suggests that BWCs are associated with reductions in use of force, these findings are not universal across studies (Lum et al. 2019; White et al. 2019a). For instance, BWCs did not impact officer use of force in Denver (CO), Hallandale Beach (FL), Birmingham (UK), Milwaukee (WI), Edmonton (Canada), or Washington DC (Ariel 2017; Headley et al. 2017; Henstock and Ariel 2017; Peterson et al. 2018; Stratton et al. 2015; Yokum et al. 2017). A multisite trial of BWCs in ten agencies identified no effect of BWCs on use of force overall; however, the effects of BWCs varied between null effects, decreases, and even increases in use of force across the individual agencies examined (Ariel et al. 2016). Ariel et al. (2016) suggest that the increase in use of force associated with BWCs in some agencies was due to noncompliance with experimental protocols, resulting in officer discretion to activate and deactivate their BWCs.

Most of the research studying the impact of BWCs on complaints has found that BWCs either reduce or have no impact on citizen complaints against officers (Lum et al. 2019; White et al. 2019b). Significant reductions in citizen complaints have been found for officers who wore BWCs in Las Vegas (NV), London (England), Miami (FL), Orlando (FL), and Phoenix (AZ), relative to control officers (Braga et al. 2018; Chin-Quee 2018; Grossmith et al. 2015; Hedberg et al. 2017; Jennings et al. 2015). Braga et al. (2018) suggest that this reduction could be due to a civilizing effect of BWCs on police-citizen encounters. Several studies have also found that complaints against BWC officers decreased at the same time that complaints against control officers increased, including researchers in Arlington (TX), Phoenix (AZ), Milwaukee (WI), and Spokane (WA) (Goodison and Wilson 2017; Katz et al. 2014; Peterson et al. 2018; White et al. 2017). Some researchers, however, have identified no impact of BWCs on citizen complaints (Braga et al. 2019; Headley et al. 2017; Yokum et al. 2017).

Prior BWC deployment strategies

Though many BWC studies have used rigorous experiments or quasi-experiments (Lum et al. 2019), the methodology used to deploy BWCs to officers varies across studies. The different implementation strategies used across evaluations have important implications for contextualizing the findings of this body of research. One of the major considerations in designing a BWC study is whether officers will be mandated to wear BWCs, or if officers will need to volunteer to be a part of the study and to wear BWCs. Though the use of randomly selected officers who are mandated to wear BWCs is perhaps the most common strategy for deploying and evaluating BWCs, some evaluations have used volunteers, or examined both voluntary and mandatory assignment of BWCs. For instance, a BWC evaluation in Las Vegas (NV) relied on BWC volunteers to avoid potential issues with the police union that could have delayed the study (Sousa et al. 2016). Ready and Young (2015) suggested that using volunteers can reduce “friction” and political opposition that can occur when officers are mandated

to wear BWCs. However, some researchers have raised concerns that officers who volunteer to wear a BWC could differ from officers who do not volunteer in important ways (Huff et al. 2018). Further, the use of volunteers limits the external validity of studies that rely solely on volunteer samples (Lawrence and Peterson 2019; Ready and Young 2015).

Given the increased potential for BWCs to be used to monitor officer behavior, officers who choose to wear a BWC could have different attitudes toward their agency and their supervisors than officers who do not choose to wear a BWC. Supporting this possibility, Kyle and White (2017) found that officers were more receptive toward BWCs when they had higher perceptions of organizational justice within their agencies. Similarly, some officers who declined to volunteer to wear a BWC in Las Vegas reported concerns about how the administration would use BWCs (Sousa et al. 2016). As such, volunteers could be less concerned about BWC footage being used against them than officers who do not volunteer to use a BWC. Volunteers could also be “gogetters” who are excited about the potential to use BWCs to capture additional evidence. Officers who resist BWCs could be concerned about the potential discipline associated with using a camera, or they could want to have their activities, or lack thereof, remain free of supervisor review. In short, officers who volunteer to wear BWCs and those required to do so could differ in qualitative ways that may not be easy to capture and compare statistically. These potential differences in deployment have important implications for understanding the impact of BWCs on officer behavior.

As previously mentioned, the impact of BWCs has been mixed across prior studies, and it is unknown whether different BWC deployment strategies or different research settings could be driving the inconsistent findings. In terms of proactivity, studies that mandated officers to wear BWCs resulted in decreased proactivity in Milwaukee (Peterson et al. 2018), increased proactivity in Spokane (Wallace et al. 2018), and no change in proactivity in Tempe (White et al. 2018). In terms of arrest, studies involving officers who volunteered to participate resulted in decreased arrests in one Southwestern US police department (McClure et al. 2017) but increased arrests in the Las Vegas Metropolitan Police Department (Braga et al. 2018). Similar reductions in use of force were identified for officers who were mandated to wear BWCs in Orlando (Jennings et al. 2015) and those who volunteered to wear BWCs in Tampa (Jennings et al. 2017). Finally, reductions in complaints were identified for both officers mandated to wear BWCs in Denver (Ariel 2017) and those who volunteered to wear BWCs in Arlington (Goodison and Wilson 2017).

Only two studies to date have examined potential differences between officers who were mandated and officers who volunteered to wear BWCs in the same agency. In their study of BWCs in Mesa (AZ), Ready and Young (2015) found that BWC volunteers ($n = 25$) were more likely to write citations than mandated officers ($n = 25$). They did not identify any differences between volunteers and mandated officers in terms of warnings, stop-and-frisks, arrests, or officer-initiated encounters (Ready and Young

2015). However, they did find that officers who volunteered to wear a BWC were significantly more likely to perceive the BWC as helpful in individual incidents. Their findings suggest that the way officers are assigned to wear a BWC could influence the impact of the BWC on officer behavior and attitudes toward BWCs. In their study of officer perceptions of BWCs in the Phoenix Police Department, Huff et al. (2020b) identified reductions in officer favorability toward BWCs for volunteers and mandated officers after BWCs were deployed, though mandated officers experienced greater reductions in favorability. These findings point to the need for additional research comparing the impact of BWCs between officers who volunteer and those who are mandated to wear BWCs.

In addition to various BWC deployment strategies across evaluations, the unit of analysis has varied across prior studies as well. Most researchers have examined the impact of BWCs at the officer level (Braga et al. 2018; White et al. 2018; Yokum et al. 2017). Other researchers argue for the use of shift-based randomization, and evaluate the influence of BWCs across treatment and control shifts (Ariel et al. 2015, 2019). Fewer researchers have examined the influence of BWCs using individual police/citizen contacts as the unit of analysis (Hedberg et al. 2017; Ready and Young 2015; Wallace et al. 2018).

Of the evaluations using officers as the unit of analysis, Braga et al. (2018) identified increased arrests in Las Vegas, though Yokum et al. (2017) did not identify any differences in arrests in the DC Metropolitan Police Department. Of those studies using shifts as the unit of analysis, Ariel et al. (2015) identified decreased use of force in Rialto (CA), but no overall effect of BWCs on use of force using the results of ten shift-based evaluations in agencies across the world. Finally, those studies using individual incidents as the unit of analysis have identified no influence of BWCs on arrests in Spokane or Phoenix (Hedberg et al. 2017; Wallace et al. 2018), though BWCs were associated with a significantly greater likelihood of citations in Mesa (Ready and Young 2015). As such, prior studies have resulted in inconsistent findings even when the same unit of analysis has been used.

The use of incidents as the unit of analysis has a number of advantages. First, it increases statistical power. Even in agencies with small numbers of officers, individual officers respond to a substantial number of incidents. This can facilitate the evaluation of a large number of incidents in general and could further be used to examine the outcomes of incidents nested within responding officers to assess the impact of BWCs across different officers. Second, the use of incidents enables researchers to account for the characteristics of the individual situation. Third, as noted by Ariel et al. (2019), aggregating outcomes to the officer level can result in contamination when incidents involve multiple officers from separate treatment conditions. As a result, some incidents that would be included in aggregate counts for one officer could also be included in counts for one or more other officers (Hedberg et al. 2017). This is a form of treatment migration, wherein some cases would receive treatment that they were not randomly

assigned to receive (Gartin 1995). Namely, control officers would experience being filmed by/working with a BWC officer. Using incidents as the unit of analysis enables researchers to examine the impact of this contamination directly (e.g., Wallace et al., 2018). Given the increasing debate about contamination in different BWC evaluation designs, the ability to control for contamination at the incident level improves upon prior evaluations that have not been able to account for this potential. Finally, the use of incidents enables an examination of whether a BWC was actually activated during an encounter. Whether or not a BWC is turned on, regardless of whether an officer is wearing a BWC, has been associated with different effects (Hedberg et al. 2017). This consideration is particularly important because prior research has identified large variation in BWC activation rates across individual officers in Anaheim (CA) (Lawrence et al. 2019). As such, the examination of the impact of BWCs on individual incidents addresses concerns about treatment dilution if officers are not activating their BWCs as intended.

Methodology

The current study relies on data collected as part of a randomized controlled trial (RCT) of BWCs in the Phoenix Police Department (PPD). We specifically examine the influence of BWCs on officer-initiated activity, arrests, officer use of force, and citizen complaints filed against officers using individual incidents as the unit of analysis. We further control for whether an officer was randomly selected and volunteered to wear a BWC, or was randomly selected and mandated to wear a BWC.

Phoenix is the capital of Arizona and is located in the center of the larger Phoenix metropolitan area, which is comprised of more than 4.8 million people. Phoenix is one of the fastest growing cities in the USA, with a population close to 1.7 million. Phoenix is primarily comprised of white (43.3%), Hispanic (42.5%), and Black (6.9%) residents. About 20% of residents are foreign-born, and 37.3% of residents speak a language other than English at home. The median income is about \$52,000 and 20.9% of residents live below the poverty line. In 2018, the Uniform Crime Report crime index for Phoenix was approximately 43.6 crimes per 1000 residents.

The PPD has grown by roughly 15% over the past 18 years. It is currently staffed with about 3000 authorized sworn officers and more than 1000 civilian personnel. The PPD has been on the forefront of BWC technology. In 2013, the PPD was the first agency in the US to be sponsored by the Bureau of Justice Assistance to pilot test BWCs. In that study, BWCs were evaluated in Maryvale, one of the seven patrol precincts. This quasi-experimental evaluation of their program found that officers assigned to wear BWCs conducted significantly more arrests and experienced a 23% decline in complaints (compared to a 10.6% increase for control officers) (Katz et al. 2014).

Intervention design

The present study relies on a sample of PPD officers assigned to patrol units in six of the seven precincts. Patrol officers assigned to the Maryvale precinct were excluded from the study because it served as the location of the 2013 BWC pilot test. Of the 841 officers eligible for inclusion in the current study, 668 were approached and asked to participate in a survey about BWCs. We were unable to contact the remaining officers (n = 173) due to absences and temporary reassignments (vacation, sick, training, etc.). Up to three attempts were made to contact officers who were eligible to participate in the survey. Survey participation was voluntary and officers were assured that they would have the option to decline to wear a BWC, even if they agreed to participate in the survey portion of the study. Officers were informed that their employee records would be linked to their survey responses if they agreed to participate. Of the 668 approached officers, 467 participated in the survey. This represents a 56% response rate for eligible officers and a 70% response rate among contacted officers.

BWCs were then deployed to officers in two phases, a volunteer phase and a mandated phase (see Fig. 1 for intervention design). In the volunteer phase, the research team randomly selected 144 officers from the pool of 467 officers who participated in the survey and asked them to voluntarily wear a BWC. Forty-seven of the randomly selected officers agreed to wear a BWC (BWC volunteers). Officers who declined to voluntarily wear a BWC were replaced by another randomly selected officer who had not previously been asked to wear a BWC from the same precinct. The replacement officer then had the option to volunteer to wear a BWC, or to decline to do so (n = 97 officers declined; BWC resisters).

Due to project related time constraints, the PPD elected to mandate officers to wear the remaining BWCs. In the mandated phase, all of the officers who had not agreed to volunteer to wear a BWC were randomized into either a treatment or a non-treatment condition. Those who were randomly selected during the mandated phase were required to wear a BWC without the option to decline (n = 35; BWC mandated). One of the officers who was randomly selected and mandated to wear a BWC had initially been a BWC resister. This officer was excluded from the analysis. Outside of the study protocol, eight officers were nonrandomly selected to wear a BWC by their precinct commander and were excluded from the analysis. All of the officers who were randomly selected to wear a BWC as part of the study (including BWC resisters) were coded as intent-to-treat officers because they were randomly assigned to the treatment condition. The 281 officers who were not asked or assigned to wear a BWC during either the volunteer or the mandated phase serve as the control group. Six officers (4 controls and 2 resisters) were removed from the study because they were reassigned outside of patrol during the study period. The final sample used in these analyses includes incidents involving 47 BWC volunteers, 94 BWC resisters, 34 BWC mandated officers, and 277 control officers. All BWCs used in the study were deployed on May 24, 2017.

Figure 1. Intervention design

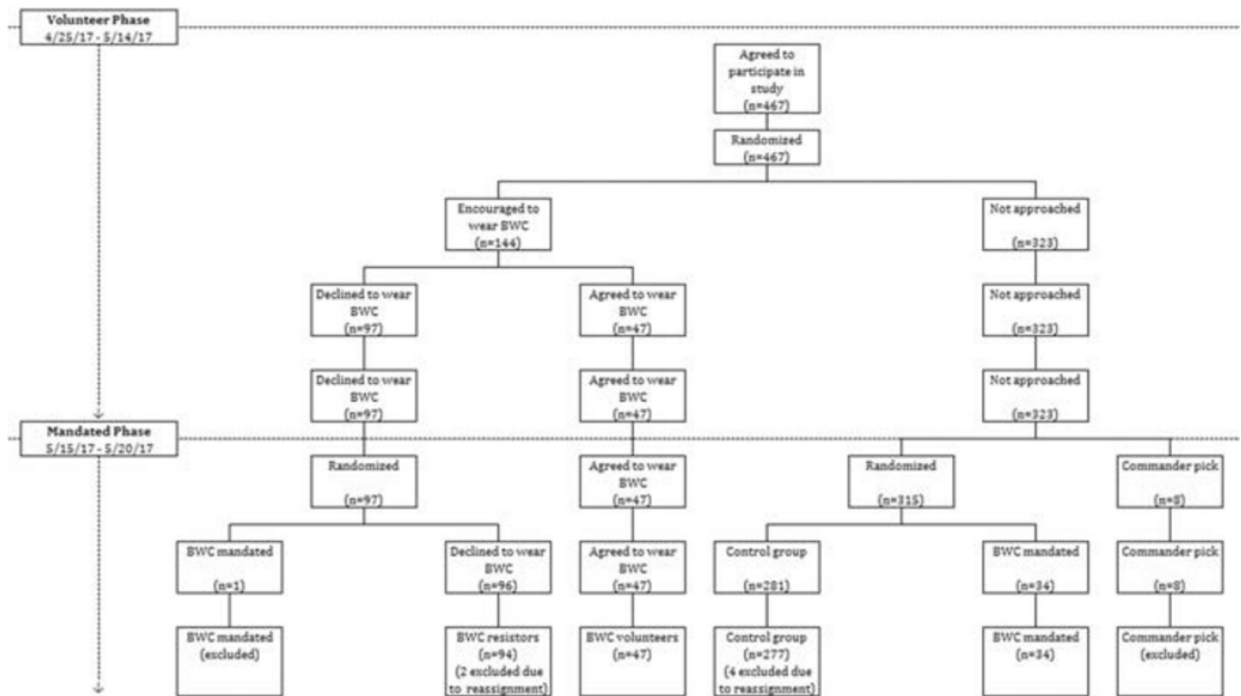

The PPD BWC policy was first established as part of the 2013 pilot study. That policy stated that “all officers and supervisors who arrive on a scene or engage in an enforcement contact must place their VIEVU camera in the on/record mode as soon as it is safe and practical to do so” (Katz et al. 2014, p. 17). This policy was updated during our study period. The revised Phoenix Police Department Info Center Operations Orders (2018) reads “Users must activate their body-worn camera by placing the camera in the ‘On/Record’ mode upon receiving a call for service and/or prior to engaging in any investigative or enforcement contact” (Operations Order 4.49). As such, officers assigned to wear BWCs as part of this study were expected to activate their BWC in all citizen encounters throughout the study. Officer compliance with the BWC activation policy is assessed by their direct supervisor who randomly selects and inspects one video for each officer assigned to wear a BWC each week. The inspections lieutenant for each precinct also randomly selects and reviews at least one video captured using a BWC on a monthly basis and includes their findings in the Monthly Inspections Report.

Data

The present study relied on computer-aided dispatch (CAD) data, arrest data, use of force reports, complaints, and BWC metadata. For the purposes of this study, we examine the 18 months after BWCs were deployed to randomly selected PPD officers (May 24, 2017, through November 23, 2018). The CAD data included all PPD incident reports for crime and disorder events for 18-months post-camera implementation.

These data include records for dispatched incidents as well as officer-initiated contacts. Officer-initiated contacts are proactively initiated by an officer who observed an event and chose to contact an individual, as opposed to responding to a citizen request for service (either through 911, an online report, or flagging an officer down). Arrest data were used to identify those incidents that resulted in an arrest.

The PPD's Standard Operating Procedures require an official use of force report to be completed if the incident involved a TASER, intermediate control techniques (e.g., hard empty hands, flashlights), carotid control techniques, and/or deadly force. The data used in this evaluation do not include the use of soft empty hands, restraining devices, and tripping/tackling because these incidents are only recorded through a use of force report in the event of an alleged injury. All use of force reports were created by the involved officers' supervisor. Complaint data were gathered from PPD's Professional Standards Bureau and included all complaints, regardless of the source of the complaint (e.g., citizen, supervisor, website). Complaints about events that were unrelated to an officers' job performance (e.g., complaints about officer behavior off duty) were removed from the analysis. Finally, metadata were collected from the BWC vendor to obtain a record of every BWC activation during the study period. This enables us to examine whether a BWC was activated in each individual police-citizen contact.

Dependent variables

Our dependent variables are binary measures for each of the following: officer-initiated contact, arrest, use of force, and citizen complaint (coded as 0 = no; 1 = yes).

Independent variables

Our primary independent variables are measures of the proportion of responding officers assigned to wear a BWC and BWC activation. The proportion of responding officers assigned to wear a BWC is a continuous variable ranging from 0 = all responding officers assigned to the control condition to 1 = all responding officers assigned to the treatment condition. As such, this variable captures treatment exposure, with incidents that did not involve any responding officers assigned to wear a BWC (i.e., the treatment) being coded as 0 and those incidents in which every responding officer was assigned to wear a BWC being coded as 1. Using a proportion also allows us to account for incidents involving varying levels of contamination. For example, an incident involving one officer assigned to wear a BWC and one officer assigned to the control condition is given the value 0.5; an incident involving two control officers and one BWC officer is given a value of 0.33. BWC activation measures whether a BWC was activated during an individual police-civilian encounter (coded as 1 = BWC activated; 0 = no BWC activation). The BWC activation variable was created by merging the BWC metadata with the CAD data to identify all incidents that resulted in a BWC being activated over the study period.

We also account for incident type using a series of binary variables created from the radio codes in the CAD data: violent offense, property offense, subject/vehicle stop,

and other offenses using violent incidents as the reference category (all incident types coded as 0 = no; 1 = yes). Violent incidents include fights, domestic violence, and assaults. Property incidents include thefts and residential burglaries. Subject/vehicle stops include subject stops and vehicle stops. Other incidents are those that do not fit into any of these categories, including welfare checks, suspicious persons, and noise disturbances. Though officers were randomly assigned to wear a BWC, it is likely that there are differences between officers who agreed to volunteer to wear a BWC and officers who were mandated to wear a BWC. As such, we include a BWC volunteer variable in all of our analyses to account for these potential differences (coded as 1 = volunteer; 0 = non-volunteer).

Analytic strategy

We first present the descriptive statistics and the bivariate results for incidents that involved officers who were assigned to wear a BWC, incidents that involved a BWC activation, and incidents involving control officers. All bivariate differences are examined using chi-square tests for categorical variables and t-tests for continuous variables, using incidents involving control officers as the reference category.

We then estimate two separate multivariate models for our outcomes of interest. We first assess the impact of BWCs using an intent-to-treat approach (ITT, Model 1). For the ITT approach, we use a probit path model predicting each outcome using the proportion of responding officers assigned to wear a BWC (ranging from 0 = none of the responding officers to 1 = all of the responding officers), the incident type variables, and whether the responding officer was a BWC volunteer, offset by the number of responding officers, to predict each outcome. In essence, the first portion of the analysis is used to examine the impact of assigning BWCs to officers. While informative, this portion of the analysis assumes full compliance with the treatment which could lead to inaccurate results if BWCs were not used as assigned (see discussions in Heckman 1997; Hedberg et al. 2017).

Second, we estimate the impact of the treatment on the treated using an instrumental variable analysis (TOT, Model 2). The TOT portion of the analysis produces the impacts of BWCs for incidents in which they were used as intended. For the TOT approach, we use a probit path model predicting each outcome using BWC activation, the incident type, and the BWC volunteer variables, offset by the number of responding officers. The BWC activation variable in Model 2 is instrumented by the proportion of responding officers assigned to wear a BWC, the incident type, and the BWC volunteer variables. We instrument the BWC activation variable because even though the treatment assignment itself was random and is uncorrelated with any of the other covariates in the model (i.e., exogenous), officer compliance with the treatment could be related to the type of incident or whether the officer volunteered to wear a BWC. As such, direct paths between these covariates and both the BWC activated variable and the outcome variable are used to ensure that the results are doubly robust. Essentially, the second portion of the analysis identifies the effect of BWCs on incidents

involving officers who were assigned to wear a BWC and who activated their BWC, as compared to incidents involving officers who were assigned to wear a BWC but did not activate their BWC, and incidents in which the responding officer was not assigned to wear a BWC. The probit path models used to estimate the ITT and TOT results are shown in Fig. 2.¹ Appendix 1 more fully describes the use of instrumental variables within path models to estimate TOT effects and provides an example of the approach.

The use of instrumental variables for the TOT analysis addresses two common concerns related to BWC research. First, BWC researchers have engaged in debate about the most appropriate research designs to limit the effects of contamination that occurs when BWC officers respond to the same incidents as control officers. This can be considered a form of treatment migration because officers in the control condition also experience the effects of the treatment (i.e., being videoed) in those incidents. The second issue this approach addresses is treatment dilution that occurs when officers do not comply with activation policies (i.e., officers wearing BWCs might not activate them during every incident to which they respond). Angrist (2006) argues, “the simplest and most robust solution to the treatment-dilution and treatment-migration problems is instrumental variables” (p. 28). Further, using instrumental variables analysis accounts for relationships between treatment compliance and unmeasured residuals that might also influence the outcome of individual police-citizen contacts. As such, this approach is doubly robust because the covariates that are used to predict the outcomes of police encounters are also used to predict BWC activation. Evaluating the influence of the proportion of responding officers assigned to wear a BWC and BWC activation on the outcomes of individual incidents allows us to more precisely measure the impact of BWC use, in addition to BWC assignment, as previously suggested in Hedberg et al. (2017).

Findings

The descriptive results presented in Table 1 reveal several notable differences between incidents that involved officers who were assigned to wear a BWC, incidents that involved a BWC activation, and incidents responded to by control officers. Bivariate analyses showed that incidents involving officers assigned to wear a BWC were significantly more likely to involve violent offenses (16.9% vs. 16.6%; $p < 0.01$) and subject/vehicle stops (22.5% vs. 22.0%; $p < 0.01$), but were less likely to involve

¹ Given that individual incidents could involve multiple responding officers, we additionally estimated all of our models using bootstrapped standard errors (similar to the methods used in Hedberg et al. 2017). Estimating the standard errors using sub-samples created through bootstrapping calculates the standard errors based on an empirically derived sampling distribution, as opposed to assuming independence between cases. Due to the potential for responding officers (either in isolation or combination) to influence the outcomes of individual incidents, using bootstrapped standard errors is an important robustness check. We did not identify any meaningful differences in the results in any of the models using the bootstrapped standard errors compared to traditionally estimated standard errors. For simplicity, we present the results without the bootstrapped standard errors.

property offenses (25.2% vs. 26.0%; $p < 0.01$), relative to control incidents. Incidents that involved a BWC activation were significantly more likely to involve violent offenses (20.7% vs. 16.6%; $p < 0.01$) and property offenses (28.8% vs. 26.0%; $p < 0.01$), but were less likely to be subject/vehicle stops (19.2% vs. 22.0%; $p < 0.01$) or other offenses (31.4% vs. 35.5%; $p < 0.01$), relative to controls.

Figure 2. Probit path models

Model 1 - ITT

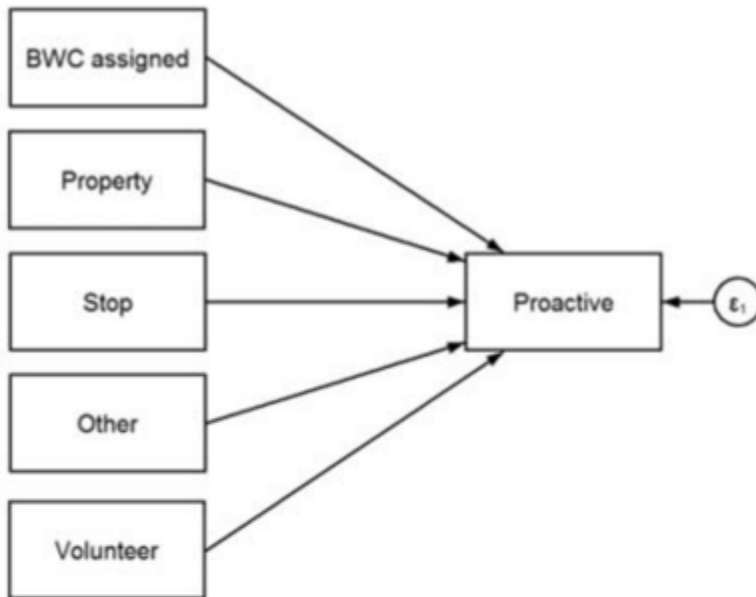

Model 2 - TOT using instrumental variable

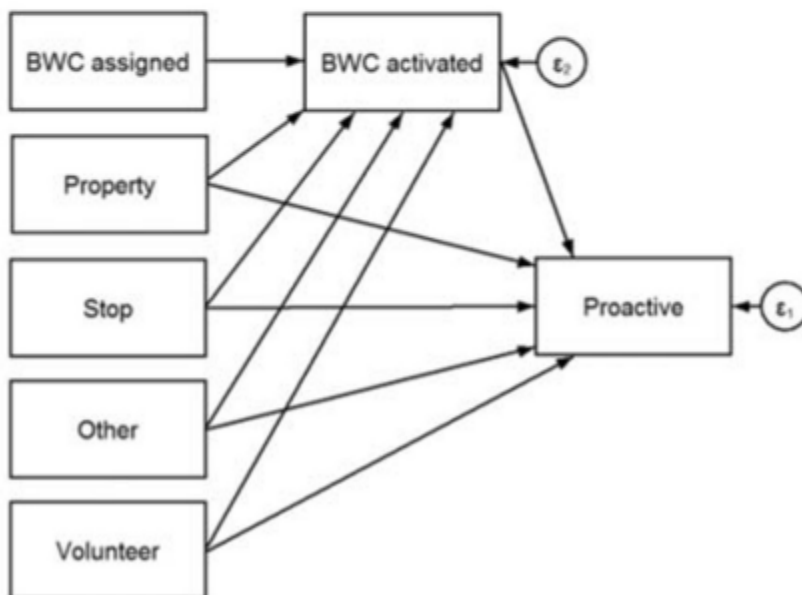

Bivariate differences in the outcome variables suggest that incidents involving officers assigned a BWC (18.1%) and incidents involving a BWC activation (14.2%) were significantly less likely to be officer-initiated than control incidents (18.0%, $p < 0.01$). Incidents involving officers assigned to wear a BWC (27.5%) and incidents involving BWC activation (34.8%) were significantly more likely to result in arrest than control incidents (27.0%; $p < 0.01$). Use of force was significantly more likely to occur during incidents in which a BWC was activated (0.15%), relative to control incidents (0.05%; $p < 0.01$), though there were no significant differences in use of force between incidents involving officers assigned to wear a BWC and control incidents. There were no significant differences in citizen complaints across groups. BWC volunteers were involved in 29.6% of incidents in which responding officers were assigned to wear a BWC and 42.3% of incidents in which a BWC was activated. As expected, incidents involving officers assigned to wear a BWC and incidents involving a BWC activation had a significantly higher proportion of responding officers assigned to wear a BWC, relative to incidents responded to by control officers (mean = 0.91 for BWC assigned; mean = 0.78 for BWC activated; mean = 0.06 for controls; $p < 0.01$).

Table 1. Descriptive statistics

	Responding officer assigned a BWC		A BWC was activated		Responding officer assigned to control	
	<i>n.</i>	%	<i>n.</i>	%	<i>n.</i>	%
Total incidents	202,442	100.00	79,636	100.00	287,401	100
Violent incidents	34,245**	16.92	16,466**	20.68	47,568	16.55
Property incidents	50,905**	25.15	22,900**	28.76	74,670	25.98
Subject/vehicle stops	45,530**	22.49	15,270**	19.17	63,203	21.99
Other incidents	71,762	35.45	25,000**	31.39	101,960	35.48
Officer-initiated incident	36,609**	18.08	11,335**	14.23	50,566	17.59
Arrest	55,574**	27.45	27,698**	34.78	77,702	27.04
Use of force	132	0.07	117**	0.15	150	0.05
Complaint	29	0.01	16	0.02	42	0.01
BWC volunteer	60,008**	29.64	33,664**	42.27	0.00	0.00
Proportion of officers assigned a BWC—mean (std. deviation)	0.91**	(0.20)	0.78**	(0.31)	0.06	(0.16)

** $p < 0.01$, * $p < 0.05$ for chi-square tests/ t tests of association using incidents responded to by control officers as the reference category

Table 2 presents the results from the officer activity models. Model 1 presents the results using the proportion of responding officers assigned to wear a BWC and Model 2 presents the results using the instrumented BWC activation variable. The findings suggest BWC assignment (Model 1) increased the likelihood that an incident would be officer-initiated ($p < 0.01$); however, the instrumented BWC activation variable (Model 2) was associated with a reduced likelihood of officer-initiated contacts ($p < 0.01$). In both models, officer-initiated contacts were more likely to involve property incidents ($p < 0.01$), subject/vehicle stops ($p < 0.01$), and other incident types ($p < 0.01$), relative to violent incidents. BWC volunteers were significantly more likely to engage in officer-initiated activities in both models ($p < 0.05$ in Model 1; $p < 0.01$ in Model 2).

The arrest results in Table 2 suggest that the proportion of officers assigned to wear a BWC was not significantly associated with the likelihood of arrest (Model 1). However, the instrumented BWC activation variable was associated with a significantly greater likelihood of arrest ($p < 0.01$). Incidents involving a BWC activation were 1.4% more likely to result in arrest, relative to incidents that did not involve a BWC activation ($p < 0.01$). Arrests were significantly less likely to occur during subject/vehicle stops ($p < 0.01$), and other incident types ($p < 0.01$), but were significantly more likely to occur during property incidents ($p < 0.01$), relative to violent incidents in both models. Incidents involving BWC volunteers were significantly more likely to result in an arrest in both models ($p < 0.01$; a 2.5% increase in the probability of arrest).

Table 2. Probit coefficients from path models predicting officer activities

	Officer-initiated		Arrest	
	Model 1	Model 2	Model 1	Model 2
BWC activated (instrumented)		-0.34** (0.01)		0.08** (0.01)
Proportion of officers at incident assigned a BWC	0.03** (0.01)		0.01 (0.00)	
Property incident	0.43** (0.01)	0.42** (0.01)	0.07** (0.01)	0.07** (0.01)
Subject/vehicle stop	2.61** (0.01)	2.59** (0.01)	-0.64** (0.01)	-0.63** (0.01)
Other incident	0.75** (0.01)	0.73** (0.01)	-0.50** (0.01)	-0.49** (0.01)
BWC volunteer	0.02* (0.01)	0.17** (0.01)	0.10** (0.01)	0.06** (0.01)
Constant	-3.22** (0.01)	-3.16** (0.01)	-1.36** (0.00)	-1.37** (0.00)
Observations	489,843	489,843	489,843	489,843

** $p < 0.01$, * $p < 0.05$; standard errors in parentheses; violent offenses used as the reference category; offset by number of responding officers

The use of force and complaints results are presented in Table 3. The use of force results suggest that incidents involving a higher proportion of officers assigned to wear BWCs (Model 1) and instrumented BWC activation (Model 2) were significantly more likely to result in use of force ($p < 0.05$ in Model 1; $p < 0.01$ in Model 2). Both models suggest that use of force was significantly less likely to occur during property incidents ($p < 0.01$), subject/vehicle stops ($p < 0.01$), and other incidents ($p < 0.01$), relative to violent incidents. There were no significant differences in the likelihood of use of force for incidents involving BWC volunteers.

The proportion of officers assigned to wear a BWC was not significantly associated with the likelihood of a complaint (Model 1); however, the instrumented BWC activation variable was associated with a significantly lower likelihood of a complaint ($p < 0.05$; Model 2). The only other significant variable in the complaint models suggests that complaints were less likely to occur for other incident types ($p < 0.01$), relative to violent incidents.

To provide a visual representation of the impact of BWC activation on each of our outcomes of interest, we examined the predicted probability of each outcome depending on whether or not a BWC was activated (using Model 2 results). As shown in Fig. 3, the results largely suggest that the influence of BWC activation is relatively minor. Holding all other covariates at their means, incidents that did not involve a BWC activation had a 12.5% likelihood of being officer-initiated, relative to a 7.0% likelihood when a BWC was activated. Around 26.1% of incidents were expected to result in arrest when a BWC was not activated, though 28.7% of incidents that involved a BWC activation were expected to result in arrest. The likelihood of an incident resulting in use of force when a BWC was not activated was 0.04%, slightly lower than the predicted probability when a BWC was activated (0.07%). The probability of an incident resulting in a complaint was extremely low, with only 0.02% of incidents that did not involve BWC activation expected to result in a complaint, compared to 0.01% of incidents that involved a BWC activation.

Discussion

Our findings suggest that BWCs were associated with a reduced likelihood of officer-initiated contacts and complaints but a greater likelihood of arrest and use of force. As such, BWCs could be decreasing officer proactivity and complaints, but increasing more aggressive forms of policing like arrests and use of force. However, the differences were substantively small.

Our finding that BWCs decreased the likelihood of an officer-initiated contact are consistent with researchers in Milwaukee, where it was similarly reported that BWC officers conducted fewer subject stops (Peterson et al. 2018). Researchers in Boston and London also found that BWCs were associated with fewer field interviews and stops and frisks, though the differences were not significant (Braga et al. 2019; Grossmith et al. 2015). However, this is inconsistent with other researchers who have reported that

BWCs increase officer proactivity (Ready and Young 2015; Wallace et al. 2018). It is important to note that BWC volunteers were significantly more likely to engage in officer-initiated contacts, relative to officers who did not volunteer to wear a BWC. This suggests that officers who choose to wear a BWC could use them to engage in more proactive policing, while officers who are mandated to wear a camera could become more passive. Given the somewhat mixed results of BWCs on officer-initiated contacts across prior studies, our findings suggest that officer receptivity to wearing a BWC could influence the impact of the camera on their proactive behaviors.

Table 3. Probit coefficients from path models predicting use of force and complaints

	Use of force		Complaint	
	Model 1	Model 2	Model 1	Model 2
BWC activated (instrumented)		0.15** (0.04)		-0.20* (0.08)
Proportion of officers at incident assigned a BWC	0.11* (0.05)		0.03 (0.09)	
Property incident	-0.13** (0.05)	-0.12* (0.05)	-0.15 (0.09)	-0.16 (0.09)
Subject/vehicle stop	-0.17** (0.06)	-0.16** (0.06)	0.03 (0.08)	0.02 (0.08)
Other incident	-0.30** (0.05)	-0.29** (0.05)	-0.26** (0.09)	-0.28** (0.09)
BWC volunteer	-0.05 (0.06)	-0.07 (0.06)	0.02 (0.10)	0.10 (0.10)
Constant	-4.38** (0.04)	-4.38** (0.04)	-4.76** (0.07)	-4.70** (0.06)
Observations	489,843	489,843	489,843	489,843

** $p < 0.01$, * $p < 0.05$; standard errors in parentheses; violent offenses used as the reference category; offset by number of responding officers

We found that BWCs were associated with a greater likelihood of arrest, consistent with researchers in Las Vegas (Braga et al. 2018). However, this finding is inconsistent with some prior studies. Headley et al. (2017), for example, found that BWC officers in their study were more likely to conduct field contacts but were less likely to conduct arrests. They suggest that BWC officers continue to be active in responding to suspicious activities, but that they might use less formal measures to resolve incidents. Our findings suggest that the opposite could be occurring in Phoenix, given that BWCs reduced officer-initiated activities but increased arrests. As such, BWCs could limit officer discretion, if officers who wore BWCs felt like they could only respond

to civilian requests for service, and that they must use arrests as opposed to an alternative strategy to respond to incidents. As in proactivity, officers who volunteered to wear a BWC were significantly more likely to conduct an arrest relative to other officers. This again suggests that officers who choose to wear a BWC could use them to engage in more legalistic policing.

Figure 3. Predicted probabilities using TOT with the instrumental variable results

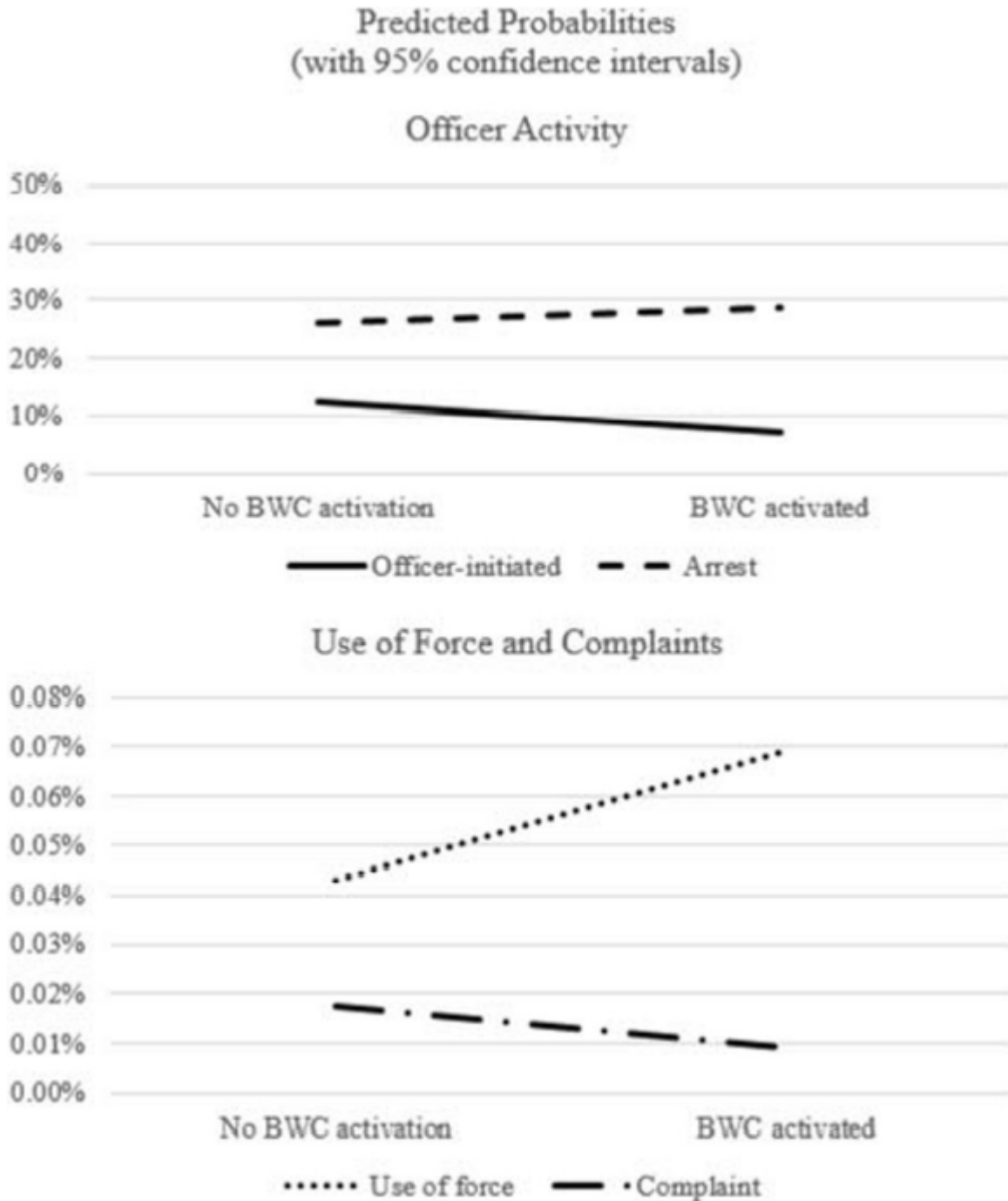

Our finding that BWCs were associated with an increase in use of force is surprising and inconsistent with several prior studies (Ariel et al. 2015; Braga et al. 2018; ChinQuee 2018). However, Ariel (2017) also found that use of force was significantly more likely for BWC officers assigned to some districts in Denver, though he identified a null effect of BWCs on use of force overall. In their review of 71 BWC studies, Lum et al. (2019) found that impact of BWCs on use of force was inconsistent across studies, with some researchers identifying decreases but others identifying null effects. There are a few potential explanations for the increase in use of force associated with BWCs. First, this could be an artifact of increased reporting of officer use of force because there is BWC footage of the incident. This is consistent with research conducted in England, which suggests that BWCs could increase the reporting of lower levels of police use of force (Henstock and Ariel 2017). Second, it is possible that BWCs could be used to capture evidence that justifies police use of force. For instance, officers who wear BWCs might be better able to document civilian resistance or aggression. As a result, officers who wear BWCs could be less hesitant to use force when it is necessary. Given the focus of the current study, we do not differentiate between different types of force or whether the force was appropriate. Future researchers should more fully examine these potential explanations.

Finally, we found that BWCs were associated with a significantly lower likelihood of a complaint. This finding is consistent with a large body of research that predominantly indicates that BWCs reduce citizen complaints (Lum et al. 2019; White et al. 2019b). Importantly, we found that this reduction only occurred when a BWC was activated, and was not related to assignment to wear a BWC alone. This suggests that for BWCs to effectively reduce complaints against the police they must be used. These results are consistent with prior research in Phoenix, which found that BWC activation had a substantially stronger effect on complaints than mere BWC assignment, though both conditions were associated with significant reductions in that study (Hedberg et al. 2017).

One of the major contributions of the current study is the use of instrumental variable analysis to more accurately assess the effects of BWCs. We improve upon studies that solely examine the effect of BWC assignment by also examining the impact of BWC activation on the outcomes of individual incidents. Though obtaining a conservative estimate of BWC assignment is important, it could provide misleading estimates of the impact of BWCs for police agencies considering the adoption of this technology. Namely, studies that take an ITT approach can result in underestimates of the causal effect of BWCs. By presenting both the results based on BWC assignment as well as the effect of BWC activation instrumented on assignment, we examine the range of impacts of BWCs on different outcomes. Because officers are unlikely to perfectly comply with BWC activation policies, the ITT results are useful in understanding a lower end threshold for anticipated treatment effects associated with the deployment of BWCs to officers. The instrumental variable results, on the other hand, present an upper end threshold, indicating the effect of BWCs on various

outcomes if officers assigned to wear BWCs activated them 100% of the time (Hedberg et al. 2017).

Our findings suggest that BWC assignment and instrumented BWC activation have similar effects on the outcomes examined, though some notable differences emerged. BWC assignment increased the likelihood of an officer-initiated contact, but BWC activation was associated with a significant decrease in the likelihood of proactivity. Though both BWC assignment and activation increased the likelihood of an arrest, only BWC activation significantly increased arrests. Both BWC assignment and BWC activation significantly increased the likelihood of use of force. Finally, BWC assignment was not associated with complaints, but BWC activation significantly reduced the likelihood of a complaint. As such, policymakers who want to maximize the effectiveness of BWCs should focus on ensuring that officers who wear BWCs are actually using them in accordance with activation policies.

We also assessed differences between officers mandated to wear BWCs and those who volunteered to do so. BWC volunteers were significantly more likely to self-initiate contacts and to conduct arrests, relative to officers who did not volunteer to wear a BWC. This suggests that volunteers could use BWCs to be more proactive and legalistic. Further, volunteers were not more likely to use force or receive complaints, suggesting that increases in activity levels for volunteers are not resulting in forceful or improper policing. As such, our findings suggest that increasing officer buy-in, prior to deploying BWCs, could also increase the utility of the technology in increasing police activity, while avoiding potentially negative effects associated with more formal policing.

The impact of contamination

One of the most enduring debates in the BWC research is the appropriate experimental design to reduce contamination. Ariel et al. (2019) argue that using officers as the unit of analysis violates the stable unit treatment value assumption (SUTVA) because officers assigned to the BWC condition could respond to the same incidents as officers assigned to the control condition, resulting in contamination. SUTVA maintains that there should be no dependency between individual units in an experiment. As such, they promote the use of shift-based randomization (Ariel et al. 2019). However, the use of shift-based randomization suffers other concerns. Ariel et al. (2015) note that because the officers in their experiment experienced both treatment and control shifts, it is possible that the findings of their study were influenced by a spillover effect. In essence, an officer assigned to wear a BWC on Monday but not to wear a BWC on Tuesday could still change their behavior on Tuesday because they experienced the treatment on Monday. This could explain why Ariel et al. (2015) identified significant reductions in use of force and complaints for both treatment and control shifts in their study.

Other scholars promote the use of officer-based randomization to reduce potential spillover effects and/or intra-unit contamination that occurs in shift-based

designs (Lawrence and Peterson 2019). Intra-unit contamination is the idea that the officers who receive the treatment in different shifts become contaminated because they experience both the treatment and control conditions, depending on the randomization of their shift on a particular day. So instead of contamination that occurs when BWC officers respond to the same incidents as control officers, the concern in shift-based designs is that the individual officers themselves are contaminated because they experience being in both the treatment and control conditions. In short, both shift-based and officer-based randomization procedures are subject to concerns surrounding contamination of treatment effects. Though some scholars advocate for shift-based designs to maximize independence between treatment and control conditions (Ariel et al. 2019), others have found that these designs are not always possible for practical reasons and instead use officer-based designs to minimize potential diffusion of treatment effects (Braga et al. 2018; Lawrence and Peterson 2019; Sousa et al. 2016).

Braga et al. (2018) suggest that the use of individual officers as their unit of analysis is justifiable given the organization of the Las Vegas Metropolitan Police Department, which, like PPD, relies on one-officer cars. In order to examine the extent of potential contamination in their study, Sousa et al. (2016) used CAD data to identify police incidents that involved both a treatment and a control officer. They found that an average of 19% of calls were contaminated each month (Sousa et al. 2016). A study in Milwaukee found that 34% of incidents involved both BWC and control officers (Lawrence and Peterson 2019). Wallace et al.'s (2018) study of BWCs in Spokane found that 49.7% of all incidents were contaminated. A study conducted in Washington DC identified a much higher contamination rate, finding that only around 30% of calls did not involve treatment officers (Yokum et al. 2017). In this study, we found that 15.7% of incidents involved responding officers from the treatment and control condition. As such, the extent of contamination in officer-based studies varies and it is important to report levels of contamination.

We attempted to minimize the effect of contamination on our findings by controlling for the proportion of officers at an incident assigned to wear a BWC. This allowed us to compare incidents that involved all control officers to incidents involving all BWC officers, as well as varying levels of contamination between these two ends of the spectrum (e.g., incidents involving 2 control officers and 1 treatment officer; 3 treatment officers and 1 control officer; etc.). To further assess the potential influence of contamination, we examined predicted probabilities for each of our outcomes of interest, given varying levels of contamination. As shown in Appendix 2, the probabilities of each outcome were not substantially different using any level of contamination examined.

As with all research conducted in applied criminal justice settings, conducting randomized-controlled trials of BWCs poses several challenges. The selection of the randomization unit is a key decision, with advantages and disadvantages surrounding both shift- and officer-based designs. As Ariel et al. (2019) state, "the choice of unit is a compromise between the best unit in principle and the optimal unit possible" (p. 571).

Given the limited number of BWCs purchased in the current study and the needs of the PPD, officer-based randomization was the most feasible option. Through examining the influence of BWCs on the outcomes of individual incidents, we attempted to minimize concerns surrounding contamination and potential spillover by accounting for whether an incident involved responding officers from separate treatment conditions. We further utilized an analytical strategy that specifically isolated the effects of treatment assignment and actual BWC use on our outcomes of interest in individual incidents. Future researchers should similarly attempt to statistically control for the potential influence of contamination to provide more accurate assessments of the impact of BWCs.

Conclusions

Like all research, our study has notable limitations. The PPD is a large police agency with a long history of BWC use in one of its precincts (see Katz et al. 2014). Further, the PPD has recently received some national attention for an increase in police shootings (Rojek et al. 2019). As such, these findings might not be generalizable to other departments that operate in other contexts. Our findings, however, are generally consistent with the larger body of BWC research. Like ours, other studies have found that BWCs decrease officer-initiated activities (Peterson et al. 2018) and increase arrests (Braga et al. 2018; Goodall 2007; Katz et al. 2014). However, unlike many prior studies, we found that BWCs increased the likelihood of police use of force. This finding could again be driven by the unique context of Phoenix and requires further evaluation. Finally, as in prior research, we identified a reduction in complaints for incidents involving BWCs (Ariel et al. 2015; Hedberg et al. 2017; Ready and Young 2015). Perhaps the most important contribution of our study is the use of instrumental variables analysis to identify the impact of BWCs on the outcomes of individual incidents. The use of a similar strategy is important for future researchers seeking to isolate treatment effects of BWCs. The use of incidents as the unit of analysis also enabled us to account for contamination and to compare outcomes between officers mandated to wear BWCs and BWC volunteers. These findings have important policy implications, as our results suggest that increasing officer compliance with BWC activation policies will maximize the benefits associated with the use of BWCs.

Funding

This work was supported by the Bureau of Justice Assistance Smart Policing Initiative Grant Program under Award No. 2015-WY-BX-0004.

Compliance with ethical standards

Ethical approval All procedures performed were conducted in accordance with the ethical standards of Arizona State University (approved ASU IRB study 00005277) and with the 1964 Helsinki declaration and its later amendments.

Appendix 1. Using path models to estimate TOT

The purpose of this appendix is to show how path models can estimate treatment on the treated impacts equivalent to typical econometric instrumental variable regression. Our example employs two dichotomous treatment indicators, but these derivations apply to any IV model. Our exposition was kept general in order to be helpful to a broader set of readers.

To estimate the so-called “treatment on the treated” impact, researchers often employ the local average treatment effect (LATE). This impact estimate involves three key variables: the outcome Y , the randomly assigned binary treatment indicator Z , and the observed treatment behavior (X).

Given an exogenous (uncorrelated with any other factors) treatment predictor z where control and treatment conditions are randomly assigned and coded as $z = \{0, 1\}$, the instrumental variable (IV) estimate is the ratio of the mean difference in the outcome by the mean difference in the instrumented behavior variable (as noted in Cameron and Trivedi (2005) as the Wald Estimator based on Wald's (1940) paper).

$$\tau_{IV} = \frac{\bar{y}_{z=1} - \bar{y}_{z=0}}{\bar{x}_{z=1} - \bar{x}_{z=0}}$$

Two-stage-least-squares

In the parlance of two-stage-least-squares, the first stage estimates

$$x = az + \varepsilon_2$$

which produces predicted values of \hat{x} , namely $\bar{x}_{z=1}$ and $\bar{x}_{z=0}$ where $a = \bar{x}_{z=1} - \bar{x}_{z=0}$. The second stage uses these predicted values in the model

$$y = b\hat{x} + \varepsilon_1$$

hence the name “2SLS.”

Path models

In the below, we show that the IV LATE estimate can also be achieved using path models estimated with structural equation model software. Essentially, x completely mediates the relationship between z and y (through model constraints). Path models estimate constrained covariance structures to sets of variables. We can visually represent the LATE model with the path model shown in Fig. 4.

In Fig. 4, the two endogenous variables, x and y , are proposed to relate to each other through two paths. The first is that the predicted value of \hat{y} is a linear function of the predicted value of \hat{x} , or $\hat{y} = f(\hat{x}) = b\hat{x}$. The second relationship is that the residuals of y , or ε_1 , are correlated with the residuals of x , or ε_2 . This figure also includes a representation of the major reason IV models are sometimes required: there is a relationship between the predictor (which is composed of both the prediction and residual, $x = \hat{x} + \varepsilon_2$) and the outcome residuals from the model, ε_1 .

Figure 4. Basic LATE path model

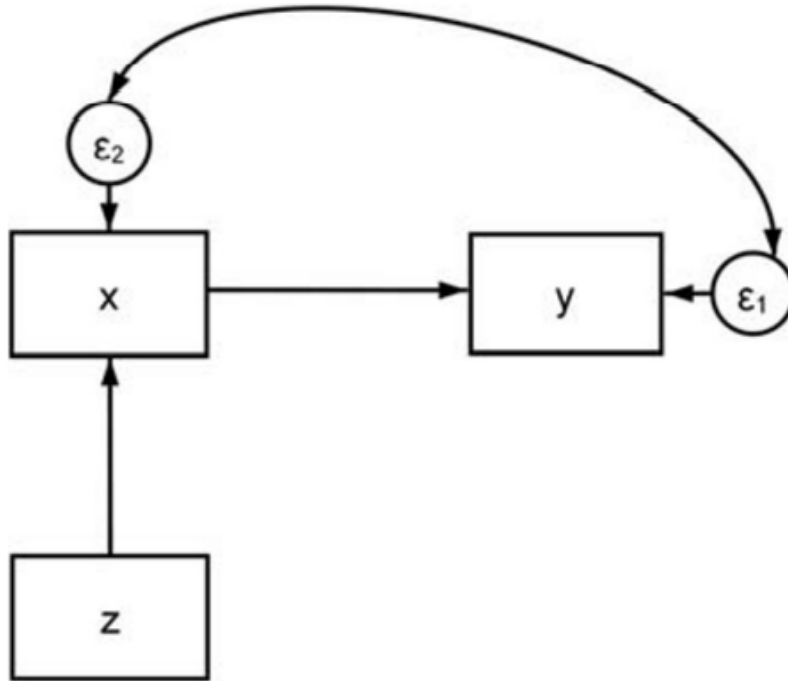

An indicator of the result of random assignment, z , is exogenous by definition and thus not correlated with the observed outcome, y . However, it is a good predictor of behavior, x , and thus the third relationship in this model is $\hat{x} = g(z) = az$.

Much of the literature on path models (e.g., Davis and Weber, 1985) note that the total impact of a chain between two variables, say z and y , are the product of the paths. Thus, the total impact of z on y in this model is the product of the first path and second path, namely by $\hat{y} = f(g(z)) = abz$ since $\hat{y} = f(\hat{x})$ and $\hat{x} = g(z)$.

Two-stage-least-squares and path models

To connect 2SLS and path models, we note that another equivalent parameterization of this estimate comprises two stages of covariances, namely the ITT impact $cov(z,y) = \hat{y}_{z=1} - \hat{y}_{z=0}$ and the covariances between behavior x and treatment assignment z , $cov(z,x) = \hat{x}_{z=1} - \hat{x}_{z=0}$, namely

$$\tau_{IV} = \frac{cov(z,y)}{cov(z,x)}$$

which can be rewritten as

$$\tau_{IV} = \frac{f(g(z))}{g(z)} = \frac{ab}{a} = b$$

In other words, the path, b , from x to y in Fig. 4 is the IV estimate τ_{IV} .

Table 4. Example data

Assigned control			Assigned treatment		
<i>z</i>	<i>x</i>	<i>y</i>	<i>z</i>	<i>x</i>	<i>y</i>
0	0	40	1	1	64
0	0	56	1	1	37
0	1	65	1	1	67
0	0	54	1	1	61
0	0	81	1	1	49
0	0	23	1	1	43
0	0	67	1	1	46
0	0	51	1	0	54
0	0	74	1	1	46
0	1	59	1	1	64

Example

Table 4 provides an example of data to be analyzed such as the above discussion. Those assigned control have a value of $z = 0$, and those assigned treatment have a value of $z = 1$. The mean of x for the control observations is .2, and the mean of x for the treatment observations is .9; $\bar{x}_{z=1} - \bar{x}_{z=0} = .7$. The mean of y for the control observations is 57, the mean of y for the treatment observations is 53.1; $\bar{y}_{z=1} - \bar{y}_{z=0} = -3.9$. This can be confirmed with the regression.

The ITT impact is thus -3.9 , and the IV impact is $\tau_{IV} = \frac{\bar{y}_{z=1} - \bar{y}_{z=0}}{\bar{x}_{z=1} - \bar{x}_{z=0}} = \frac{-3.9}{.7} = -5.571429$

This result can be confirmed by running a model in Stata using the instrumental variable regression package (`ivregress`, note the coefficient for x and its standard error).

We can also fit a path model to estimate this impact, as shown in Fig 5.

The `sem` procedure in Stata can be used to fit the path model (`gsem` can be employed for non-linear outcomes). This produces the same results as the instrumental variable regression procedure above; note the output for the coefficient of x and compare it and its standard error to the output from `ivregress`.

Also note that the coefficient for z predicting x is $\bar{x}_{z=1} - \bar{x}_{z=0} = 9-.02 = .7$ as expected.

Figure 5. Path LATE model on example data

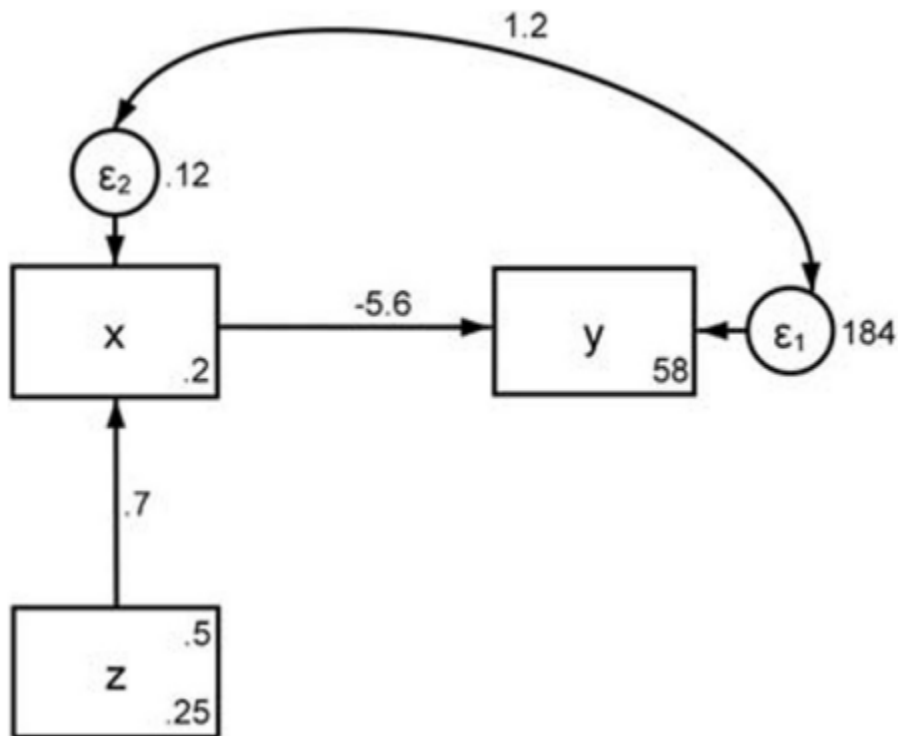

Appendix 2. Predicted probabilities based on varying levels of contamination (with 95% confidence intervals)

	Proportion of responding officers assigned to wear a BWC				
	0%	33%	50%	66%	100%
Officer-initiated	11.31%	11.47%	11.56%	11.64%	11.82%
Arrest	26.42%	26.48%	26.51%	26.54%	26.60%
Use of force	0.04%	0.05%	0.05%	0.05%	0.06%
Complaint	0.01%	0.02%	0.02%	0.02%	0.02%

Note: Results based on Model 1 for each outcome, holding all other covariates at their means

References

- Ariel, B. (2017). Criminology police body cameras in large police departments. *The Journal of Criminal Law and Criminology*, 106(4), 729–768.
<https://doi.org/10.3366/ajicl.2011.0005>.

- Ariel, B., Farrar, W. A., & Sutherland, A. (2015). The effect of police body-worn cameras on use of force and citizen's complaints against the police: a randomized controlled trial. *Journal of Quantitative Criminology*, 31(3), 509–535. <https://doi.org/10.1007/s10940-014-9236-3>.
- Ariel, B., Sutherland, A., Henstock, D., Young, J., Drover, P., Sykes, J., et al. (2016). Report: increases in police use of force in the presence of body-worn cameras are driven by officer discretion: a protocol-based subgroup analysis of ten randomized experiments. *Journal of Experimental Criminology*, 12(3), 453–463. <https://doi.org/10.1007/s11292-016-9261-3>.
- Ariel, B., Sutherland, A., & Sherman, L. W. (2019). Preventing treatment spillover contamination in criminological field experiments: the case of body-worn police cameras. *Journal of Experimental Criminology*, 15(4), 569–591. <https://doi.org/10.1007/s11292-018-9344-4>.
- Braga, A. A., Coldren, J. R., Sousa, W., Rodriguez, D., & Alper, O. (2017). The benefits of body-worn cameras : new findings from a randomized controlled trial at the Las Vegas Metropolitan Police. <https://www.ncjrs.gov/pdffiles1/nij/grants/251416.pdf>.
- Braga, A. A., Sousa, W. H., Coldren, J. R., & Rodriguez, D. (2018). The effects of body-worn cameras on police activity and police-citizen encounters: a randomized controlled trial. *The Journal of Criminal Law and Criminology*, 108(3), 511–538.
- Braga, A. A., Barao, L. M., Zimmerman, G. M., Douglas, S., & Sheppard, K. (2019). Measuring the direct and spillover effects of body worn cameras on the civility of police–citizen encounters and police work activities. *Journal of Quantitative Criminology*. <https://doi.org/10.1007/s10940-019-09434-9>.
- Cameron, A. C., & Trivedi, P. K. (2005). *Microeconometrics: methods and applications*. Cambridge University Press.
- Chin-Quee, C. J. (2018). The effects of a police body-worn camera on use of force , citizen complaints , and police productivity. In *Performance*. St. Thomas University.
- Davis, J. A., & Weber, R. P. (1985). *The logic of causal order*. Sage Publications.
- Gartin, P. R. (1995). Dealing with design failures in randomized field experiments: analytic issues regarding the evaluation of treatment effects. *Journal of Research in Crime and Delinquency*, 32(4), 425–445.
- Goodall, M. (2007). Guidance for the police use of body-worn video devices: police and crime standards directorate. <http://www.bwvsg.com/wp-content/uploads/2013/07/Police-BWV-Guidance.pdf>.

- Goodison, S., & Wilson, T. (2017). Citizen perceptions of body-worn cameras: a randomized controlled trial. <https://perf.memberclicks.net/assets/bodyworncameraperceptions.pdf>.
- Grossmith, L., Owens, C., Finn, W., Mann, D., Davies, T., & Baika, L. (2015). Police, camera, evidence: London's cluster randomised controlled trial of body worn video. London: UK https://whatworks.college.police.uk/Research/Documents/Police_Camera_Evidence.pdf.
- Headley, A. M., Guerette, R. T., & Shariati, A. (2017). A field experiment of the impact of body-worn cameras (BWCs) on police officer behavior and perceptions. *Journal of Criminal Justice*, 53, 102–109. <https://doi.org/10.1016/j.jcrimjus.2017.10.003>.
- Heckman, J. (1997). Instrumental variables: a study of implicit behavioral assumptions used in making program evaluations. *The Journal of Human Resources*, 32(3), 441–462.
- Hedberg, E. C., Katz, C. M., & Choate, D. E. (2017). Body-worn cameras and citizen interactions with police officers: estimating plausible effects given varying compliance levels. *Justice Quarterly*, 34(4), 627–651. <https://doi.org/10.1080/07418825.2016.1198825>.
- Henstock, D., & Ariel, B. (2017). Testing the effects of police body-worn cameras on use of force during arrests: a randomised controlled trial in a large British police force. *European Journal of Criminology*, 14(6), 720–750. <https://doi.org/10.1177/1477370816686120>.
- Huff, J., Katz, C. M., & Webb, V. J. (2018). Understanding police officer resistance to body-worn cameras. *Policing: An International Journal*, 41(4), 482–495. <https://doi.org/10.1108/PIJPSM-03-2018-0038>.
- Huff, J., Gaub, J. E., White, M. D., & Malm, A. (2020a). Impact of BWCs on Officer Activity: Directory of Outcomes. <https://bwctta.com/impacts-bwcs-officer-activity-directory-outcomes>.
- Huff, J., Katz, C. M., Webb, V. J., & Hedberg, E. C. (2020b). Attitudinal changes toward body-worn cameras: perceptions of cameras, organizational justice, and procedural justice among volunteer and mandated officers. *Police Quarterly*. <https://doi.org/10.1177/1098611120928306>.
- Hughes, T. W., Campbell, B. A., & Schaefer, B. P. (2020). The influence of body-worn cameras, minority threat, and place on police activity. *Journal of Community Psychology*, 48(1), 68–85. <https://doi.org/10.1002/jcop.22299>.
- Jennings, W. G., Lynch, M. D., & Fridell, L. A. (2015). Evaluating the impact of police officer body-worn cameras (BWCs) on response-to-resistance and serious external complaints: Evidence from the Orlando police department (OPD)

- experience utilizing a randomized controlled experiment. *Journal of Criminal Justice*, 43(6), 480–486. <https://doi.org/10.1016/j.icrimjus.2015.10.003>.
- Jennings, W. G., Fridell, L. A., Lynch, M., Jetelina, K. K., & Reingle Gonzalez, J. M. (2017). A quasiexperimental evaluation of the effects of police body-worn cameras (BWCs) on response-to-resistance in a large metropolitan police department. *Deviant Behavior*, 38(11), 1332–1339. <https://doi.org/10.1080/01639625.2016.1248711>.
- Katz, C. M., Choate, D. E., Ready, J. R., & Nuño, L. (2014). Evaluating the impact of officer body worn cameras in the Phoenix police department. Center for Violence Prevention & Community Safety: Arizona State University <https://cvpcs.asu.edu/content/evaluating-impact-officer-worn-body-camerasphoenix-police-department-0>.
- Kyle, M. J., & White, D. R. (2017). The impact of law enforcement officer perceptions of organizational justice on their attitudes regarding body-worn cameras. *Journal of Crime and Justice*, 40(1), 68–83. <https://doi.org/10.1080/0735648X.2016.1208885>.
- Lawrence, D. S., & Peterson, B. E. (2019). How do body-worn cameras affect the amount and makeup of police-initiated activities? A randomized controlled trial in Milwaukee, Wisconsin. *Journal of Experimental Criminology*.
- Lawrence, D. S., McClure, D., Malm, A., Lynch, M., & La Vigne, N. (2019). Activation of body-worn cameras: variation by officer, over time, and by policing activity. *Criminal Justice Review*, 44(3), 339–355. <https://doi.org/10.1177/0734016819846228>.
- Lum, C., Stoltz, M., Koper, C. S., & Scherer, J. A. (2019). The research on body-worn cameras: what we know, what we need to know. *Criminology & Public Policy*, 18(1), 93–118. <https://doi.org/10.1111/j.1461-0248.2011.01634.x>.
- McClure, D., La Vigne, N., Lynch, M. D., Golian, L., Lawrence, D. S., & Malm, A. (2017). How body cameras affect community members' perceptions of police: results from a randomized controlled trial of one agency's pilot. Urban Institute. https://www.urban.org/sites/default/files/publication/91331/2001307-how-body-cameras-affect-community-members-perceptions-of-police_1.pdf.
- Peterson, B. E., Yu, L., La Vigne, N., & Lawrence, D. S. (2018). The Milwaukee Police Department's bodyworn camera program: evaluation findings and key takeaways. PPD Info Center Operations Orders. (2018). https://www.phoenix.gov/policesite/Documents/operations_orders.pdf.
- President's Task Force on 21st Century Policing. (2015). Final Report of the President's Task Force on 21st Century Policing. Washington, DC: Office of Community Oriented Policing Services.

- Ready, J. T., & Young, J. T. N. (2015). The impact of on-officer video cameras on police–citizen contacts: Findings from a controlled experiment in Mesa, AZ. *Journal of Experimental Criminology*, 11(3), 445–458. <https://doi.org/10.1007/s11292-015-9237-8>.
- Rojek, J., Nix, J., Wolfe, S. E., Alpert, G. P., Burch, J., Grieco, J., & Robbins, T. (2019). Analysis of 2018 use of deadly force by the Phoenix Police Department.
- Rushin, S., & Edwards, G. (2017). De-policing. *Cornell Law Review*, 102(3), 721–782.
- Sousa, W. H., Coldren, J. R., Rodriguez, D., & Braga, A. A. (2016). Research on body worn cameras: meeting the challenges of police operations, program implementation, and randomized controlled trial designs. *Police Quarterly*, 19(3), 363–384. <https://doi.org/10.1177/1098611116658595>.
- Stratton, M., Clissold, P., & Tuson, R. (2015). Body worn video: considering the evidence - Final report of the Edmonton Police Service body worn video pilot project. https://www.bja.gov/bwc/pdfs/EdmontonPS_Canada_BWVFinalReport.pdf.
- Wald, A. (1940). The fitting of straight lines if both variables are subject to error. *The Annals of Mathematical Statistics*, 11(4), 284–300.
- Wallace, D., White, M. D., Gaub, J. E., & Todak, N. (2018). Body-worn cameras as a potential source of depolicing: testing for camera-induced passivity. *Criminology*, 56(3), 481–509. <https://doi.org/10.1111/1745-9125.12179>.
- White, M. D. (2014). Police officer body-worn cameras: assessing the evidence. Washington DC.
- White, M. D., Gaub, J. E., & Todak, N. (2017). Exploring the potential for body-worn cameras to reduce violence in police–citizen encounters. *Policing*, 12(1), paw057. <https://doi.org/10.1093/policing/paw057>.
- White, M. D., Todak, N., & Gaub, J. E. (2018). Examining body-worn camera integration and acceptance among police officers, citizens, and external stakeholders. *Criminology & Public Policy*, 17(3), 1–29. <https://doi.org/10.1111/1745-9133.12376>.
- White, M. D., Gaub, J. E., & Padilla, K. E. (2019a). Impacts of BWCs on use of force: directory of outcomes. <http://www.bwctta.com/resources/bwc-resources/impacts-bwcs-use-force-directory-outcomes>.
- White, M. D., Gaub, J. E., & Padilla, K. E. (2019b). Impact of BWCs on citizen complaints: directory of Outcomes. <https://www.bwctta.com/impact-bwcs-citizen-complaints-directory-outcomes>.
- Whynot, C., Nykorchuk, L., Zisis, M., & Deane, S. (2016). Toronto police service body-worn cameras.

Yokum, D., Ravishankar, A., & Coppock, A. (2017). Evaluating the effects of police body-worn cameras: a randomized controlled trial. The Lab DC Working Paper. <https://doi.org/10.1042/bst0030765>.

Publisher's note Springer Nature remains neutral with regard to jurisdictional claims in published maps and institutional affiliations.

Jessica Huff is a Senior Researcher in the Center for Violence Prevention and Community Safety at Arizona State University. Her research interests revolve around working with police agencies to evaluate programs and policies in order to improve police effectiveness and the equitable administration of justice. She has worked on several research projects with police agencies in Arizona and Northern Nevada, including randomized controlled trials of body-worn cameras and an intelligence approach to gun violence. Her work has been published in outlets including *Crime & Delinquency* and *Police Quarterly*.

Charles Katz is Watts Family Director of the Center for Violence Prevention and Community Safety and a Professor in the School of Criminology and Criminal Justice at Arizona State University. His research involves collaborating with agencies to increase their organizational capacity to identify and respond to crime effecting local communities. He currently serves as a research partner to the Phoenix Police Department to evaluate their BJA sponsored projects related to SMART policing and a Crime Gun Intelligence Center. He served as one of two primary authors of the US Department of Justice Body-Worn Camera Toolkit and currently serves as a senior advisor to the Bureau of Justice Assistance on its Body-Worn Camera Training and Technical Assistance Team.

Eric C. Hedberg is a Senior Researcher at NORC at the University of Chicago, an Accredited Professional Statistician by the American Statistical Association, and a Sociologist. Hedberg's current research includes investigating the design of education interventions. His current projects include the College Knowing and Going Survey, which employs social network data to determine the associations between the social lives of High School students in Arizona and college matriculation. He has authored several methodological pieces that have appeared in education, medical, and criminological journals. His latest writing is a SAGE "little green" book on statistical power analysis, released January 2018.